

VCSEL-850

850nm VCSEL Laser Diode in TO-46 Package

1. Feature
 - a. Oxidation process
 - b. Flat window
 - c. Monitor Photodiode
 - d. High speed 2.5Gbps

2. Application:
 - a. High-speed data communications and telecommunications applications
 - b. Gigabit Ethernet
 - c. Fiber Channel
 - d. ATM transceiver modules and system

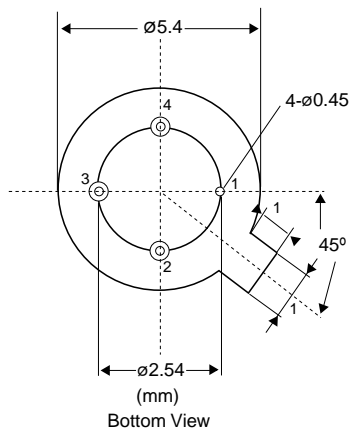
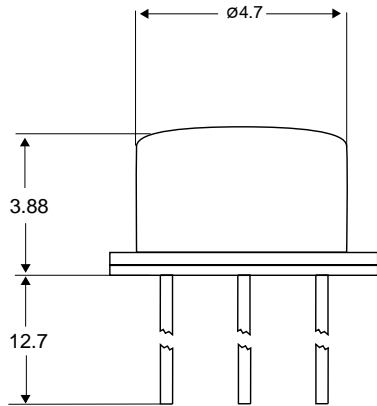

1. Case
2. VCSEL Anode
3. VCSEL Cathode/Photodiode Anode
4. Photodiode Cathode

3. Optical and Electrical Characteristics

Parameter	Symbol	Min.	TYP.	Max.	Unit	Test Condition
Peak Wavelength	λ_p	830	845	860	nm	$I_f = 8\text{mA@RT}$
Spectral Width (RMS)	$\Delta\lambda$	-	-	0.85	nm	$I_f = 8\text{mA@RT}$
Beam Divergence	Θ	-	25	30	Deg	Full width at $1/e^2$; $I_f = 8\text{mA@RT}$
Forward Voltage	V_f	1.7	1.9	2.2	V	$I_f = 8\text{mA@RT}$
Threshold Current	I_{th}	-	2.2	3	mA	-
Slope Efficiency	dP/dI	0.12	0.32	0.4	W/A	$I_f = 8\text{mA@RT}$
Optical Output Power	P_{out}	-	1.85	-	mW	$I_f = 8\text{mA@RT}$
Dynamic Resistance	dV/dI	20	40	65	Ω	$I_f = 8\text{mA@RT}$
Rise / Fall Time	t_r / t_f	-	50	100	ps	20%-80%
Jitter p-p	t_j	-	35	-	ps	-
λ_p Temperature Coefficient	$\delta\lambda_p/\delta T$	-	0.06	-	nm/°C	$T_A=0\sim 70^\circ\text{C}$, $I_f=8\text{mA}$
Operating Temperature Range	T_{op}	-5	25	80	°C	-
Monitor Current	I_m	100	-	-	μA	$I_f = 8\text{mA@RT}$

2. Maximum Ratings

Parameter	min.	Max.	Unit	Condition
Storage Temperature	-40	100	°C	-
Operating Temperature	0	85	°C	-
Continuous Forward Current	-	10	mA	-
Continuous Reverse Voltage	-	5	V	@10 μA

3. Monitoring PIN Specs

Parameter	Symbol	Min.	TYP.	Max.	Unit	Test Condition
Dark Current	I_r	-	0.2	1	nA	$V_r = 10\text{V}$
Shunt Resistance	P_p	100	200	-	G Ω	-
Breakdown Voltage	V_{br}	-	50	-	V	-
Junction Capacitance	C_p	-	40	-	pF	@ $V_r = 10\text{V}$, 10KHz